



University of Stuttgart

Microservice-tailored Generation of Session-based Workload Models for Representative Load Testing

Henning Schulz, Tobias Angerstein, Dušan Okanović, André van Hoorn

MASCOTS | October 24, 2019

PART OF THE



ContinuITY Project

<https://continuity-project.github.io/>

SPONSORED BY THE



Federal Ministry of Education and Research

Representative Load Testing Lacks in Support for Microservices

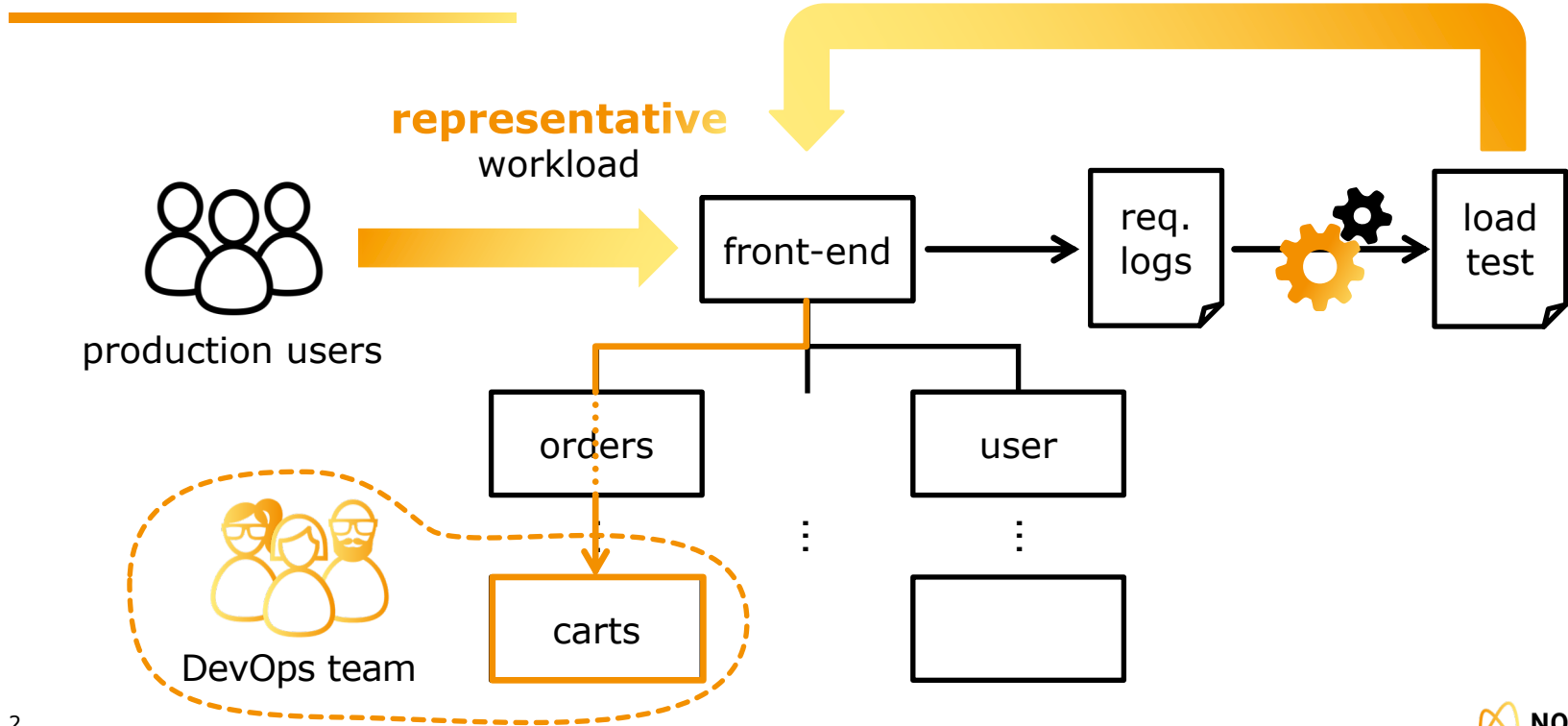

Session-based Workload

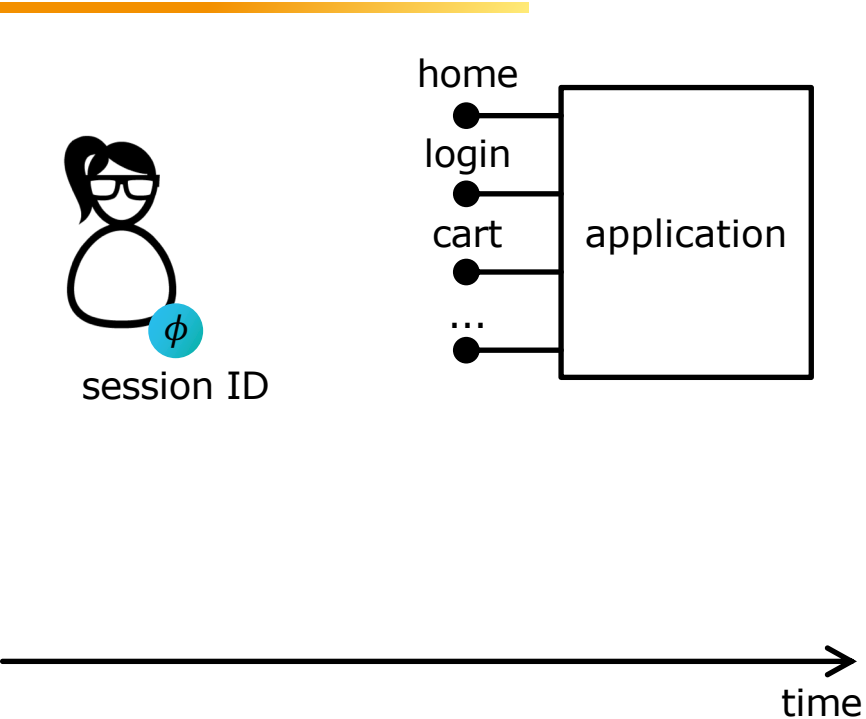

Session-based Workload

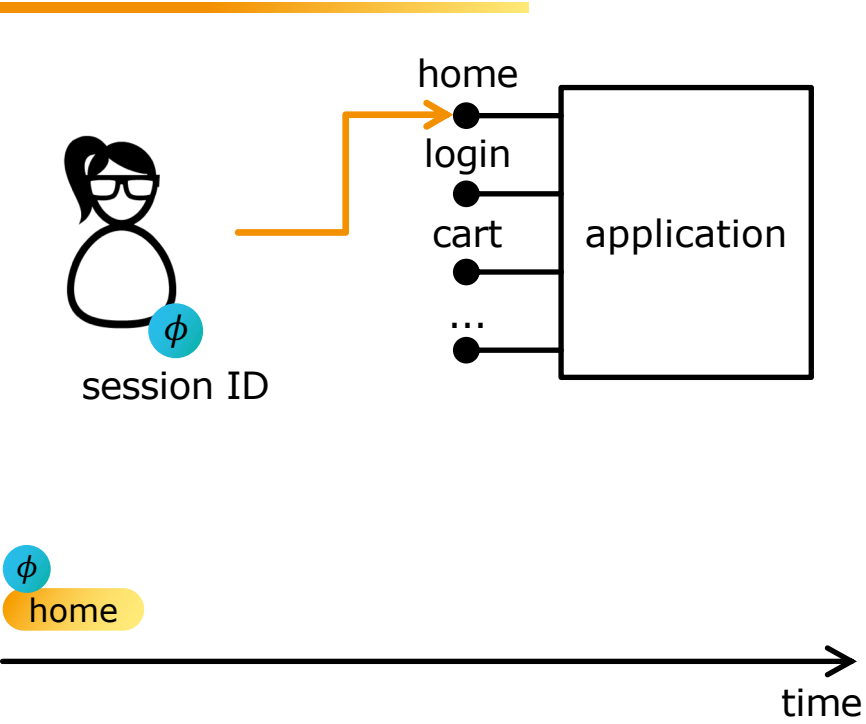

Session-based Workload

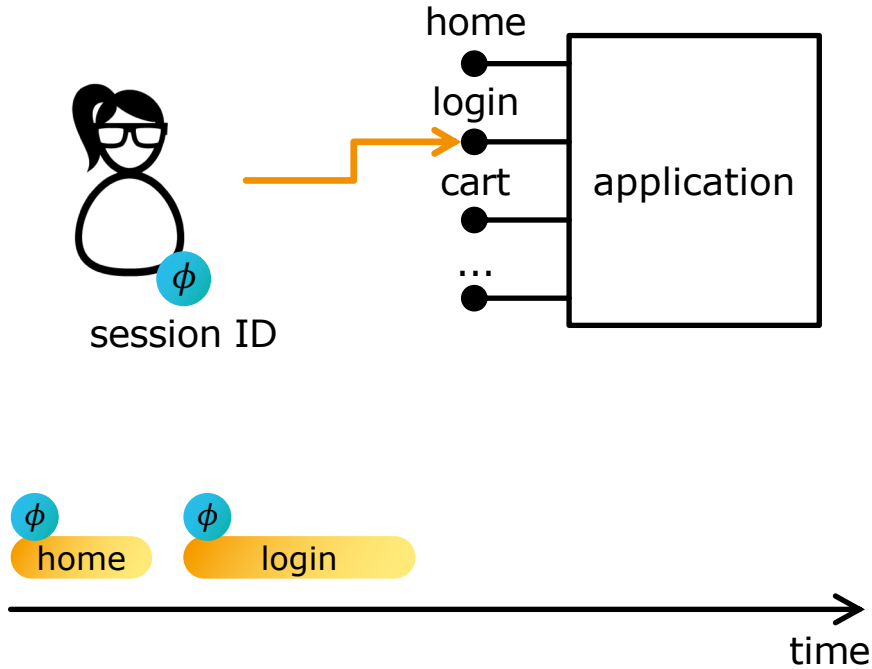

Session-based Workload

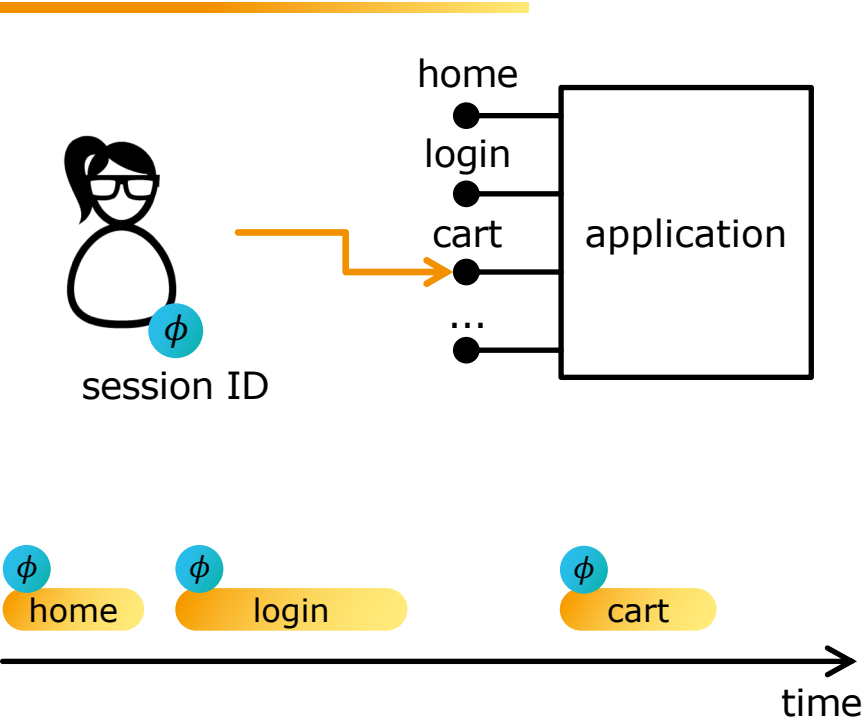

Session-based Workload

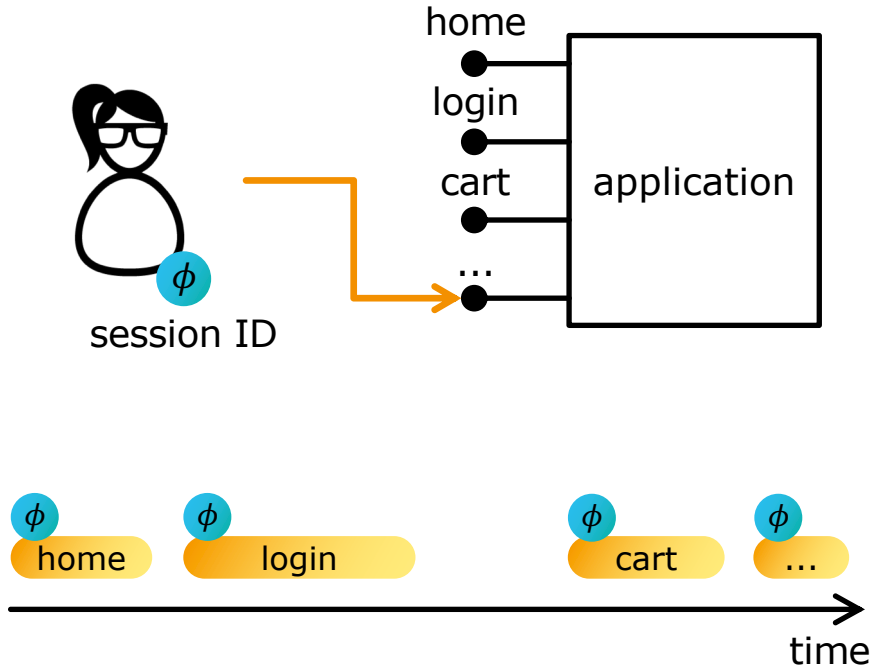

Session-based Workload

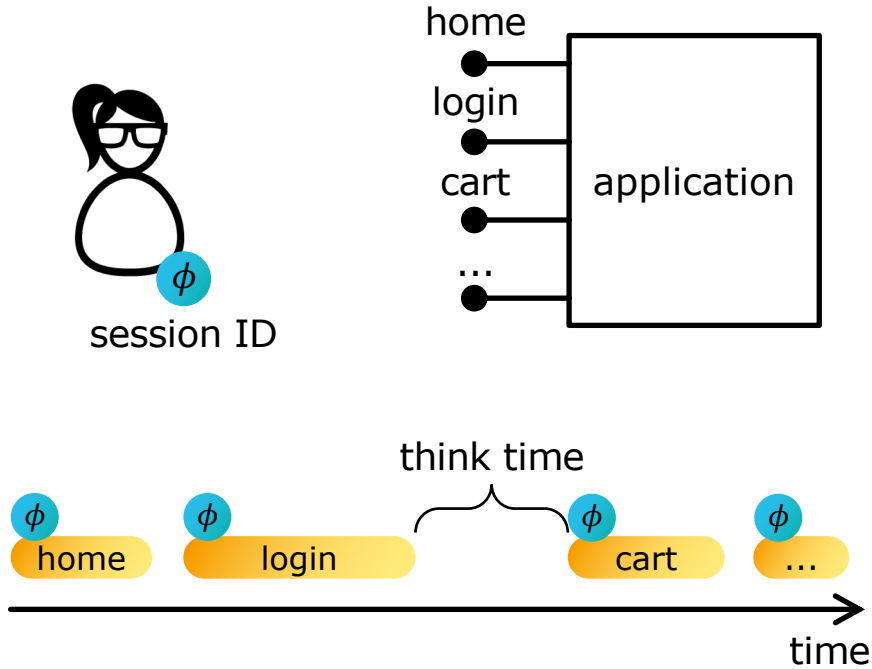

aggregation to Markov chains

probability: 0.7
think time: $\mathcal{N}(10,5)$

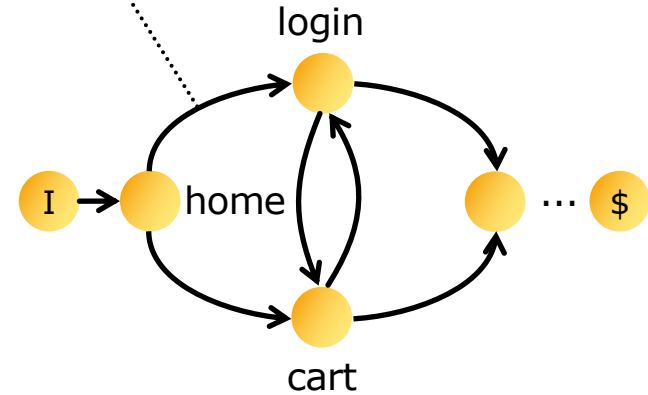

Related Work – Test Pyramid (Cohn, 2009)

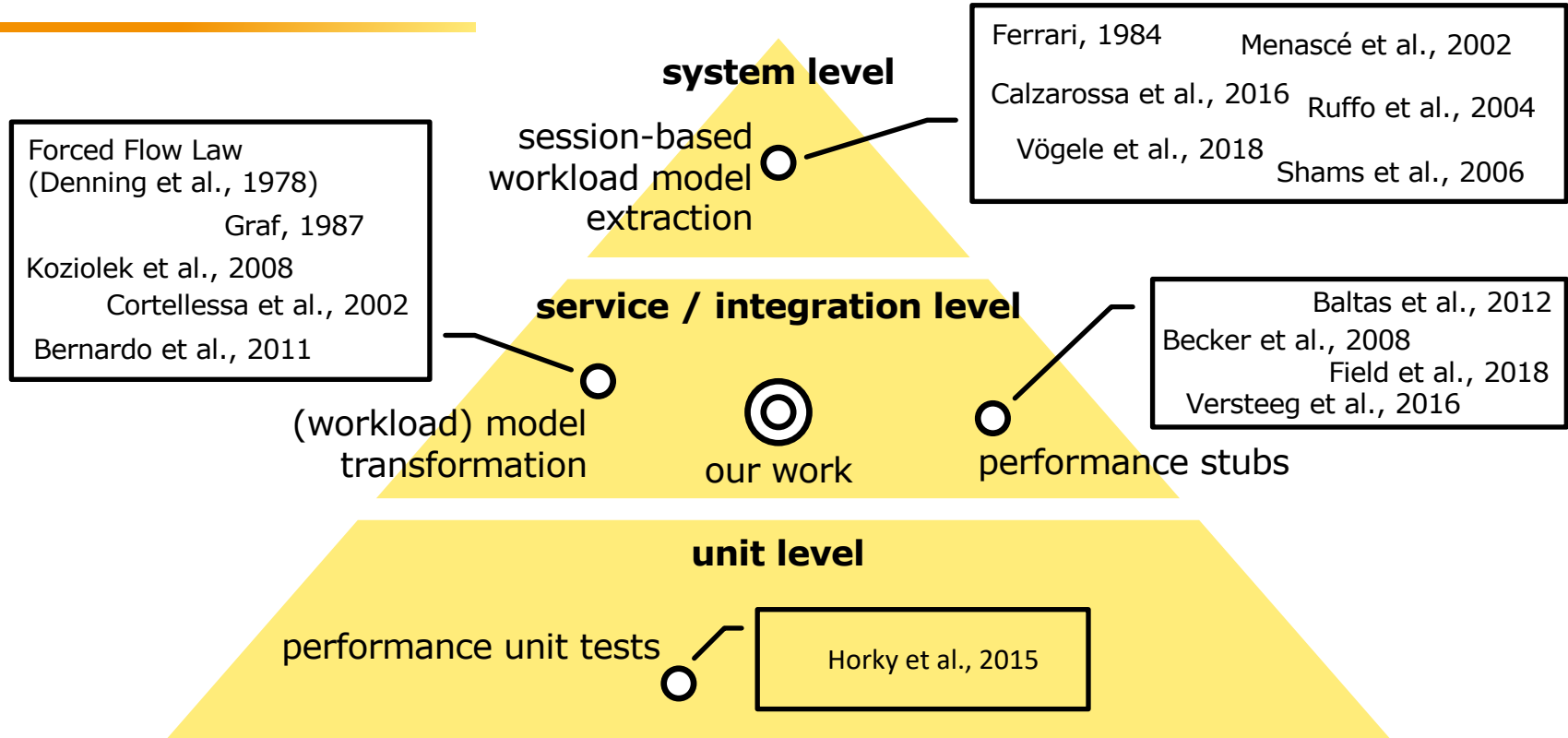

Two Possible Solutions

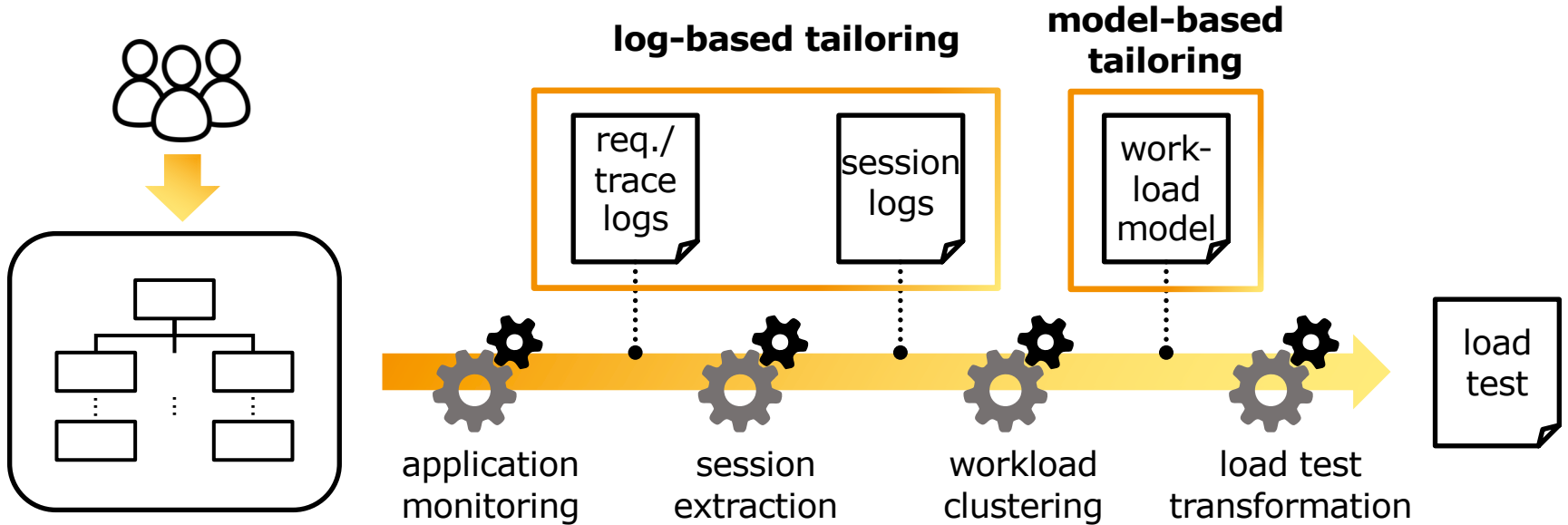

Log-based Tailoring

request / trace logs

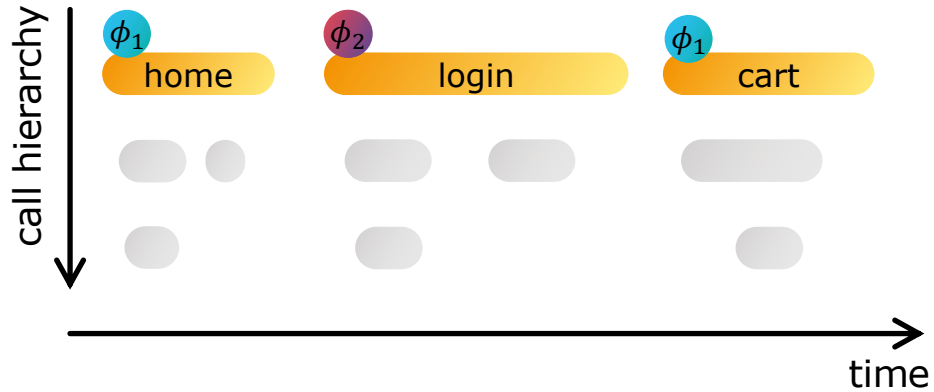

workload model

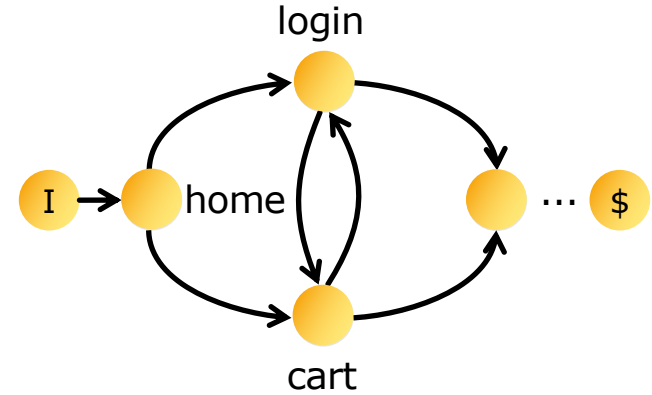

Log-based Tailoring

request / trace logs

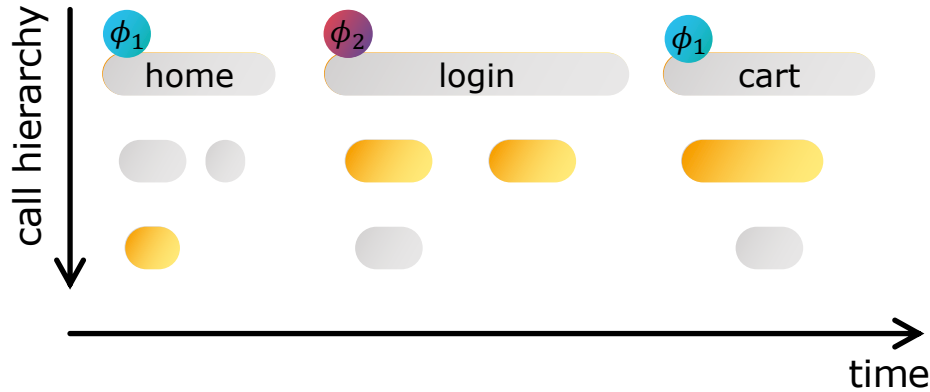

workload model

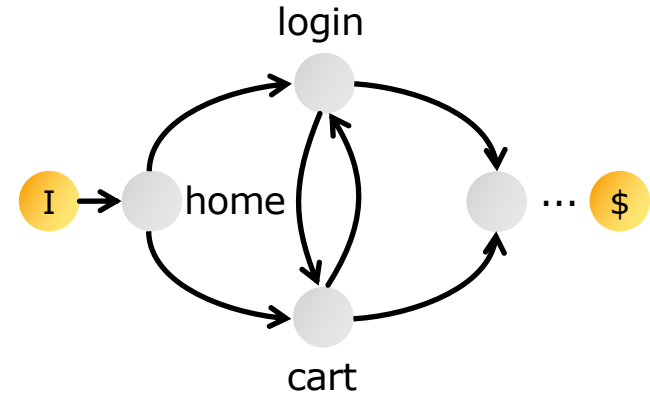

Log-based Tailoring

request / trace logs

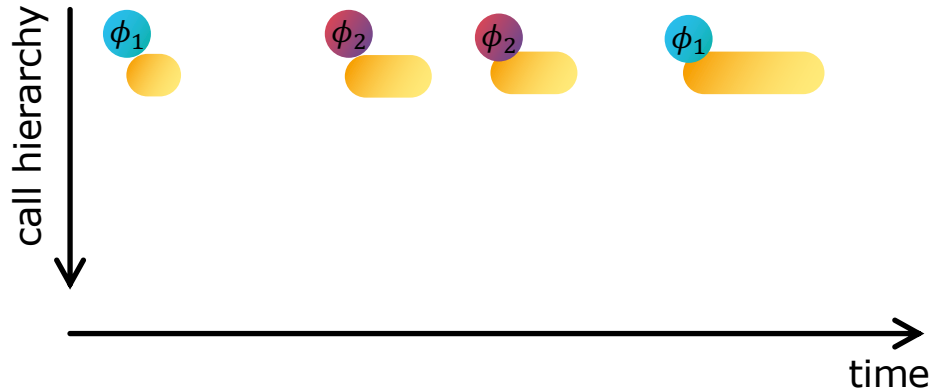

workload model

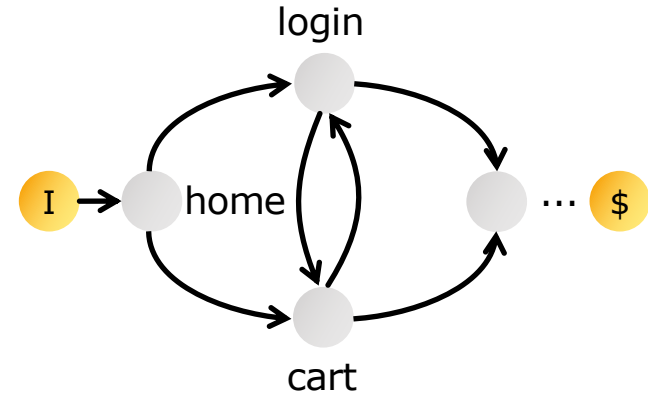

Log-based Tailoring

request / trace logs

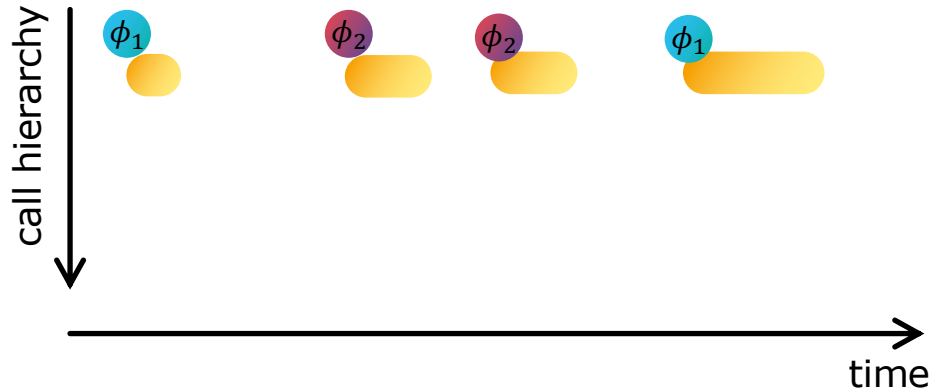

workload model

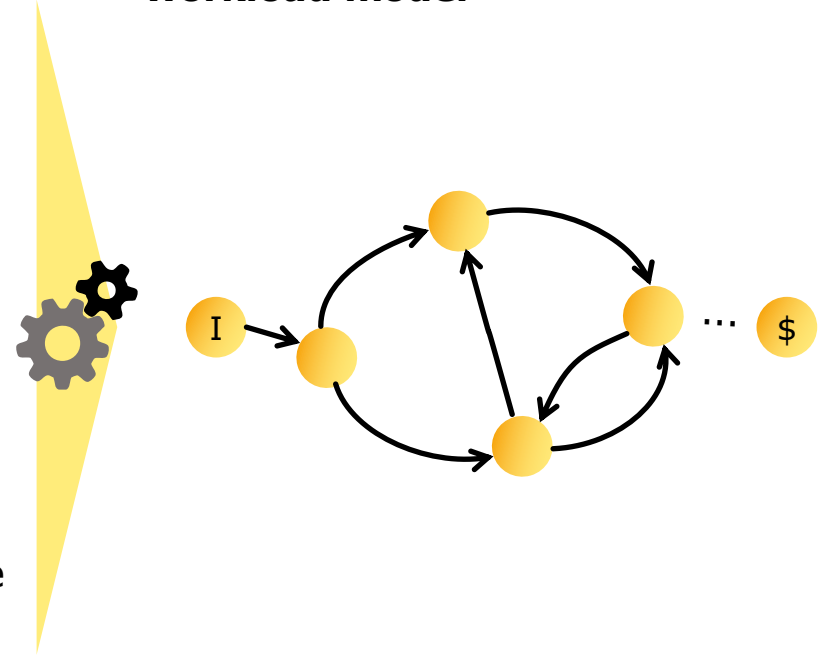

Model-based Tailoring

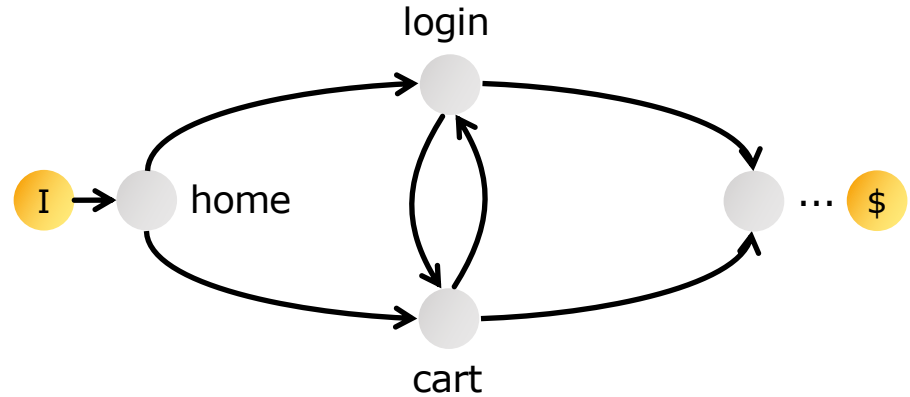
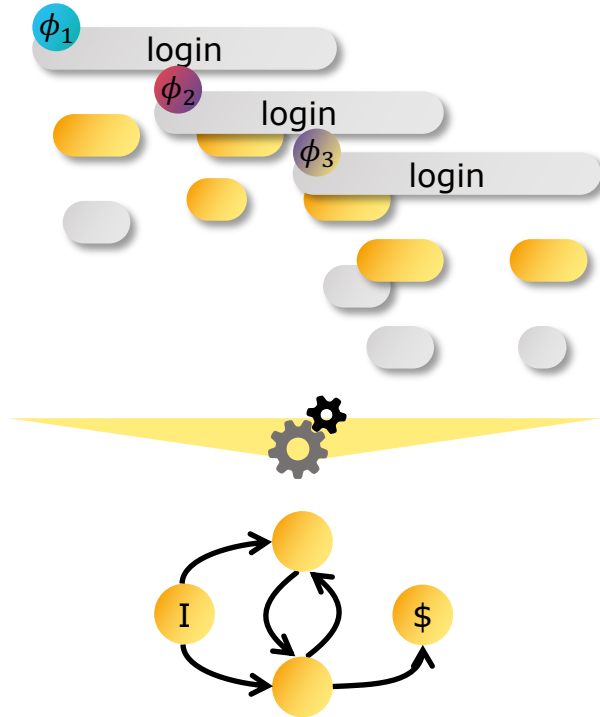

Model-based Tailoring

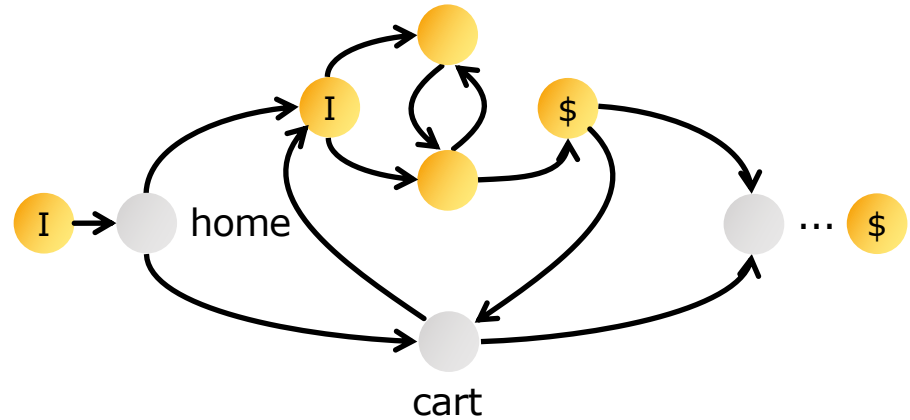
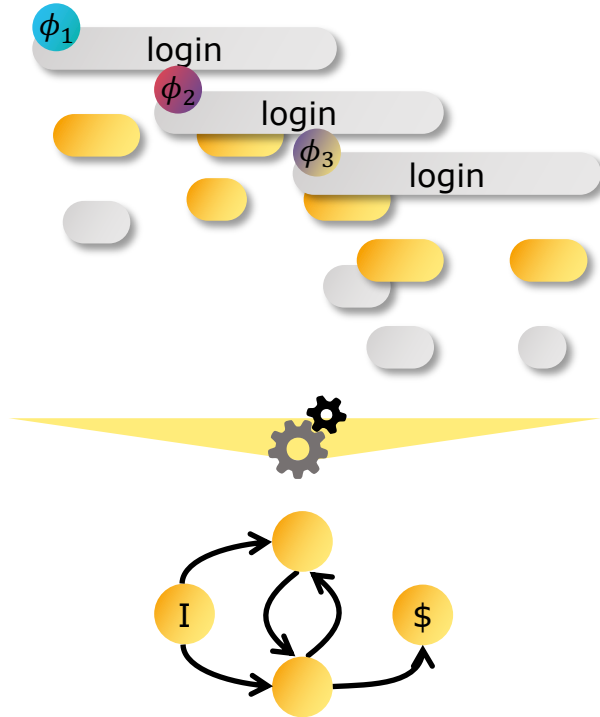

Model-based Tailoring

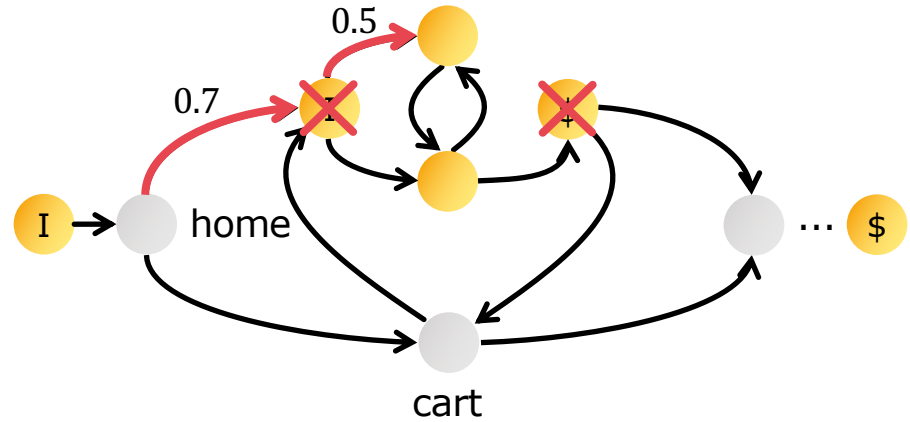
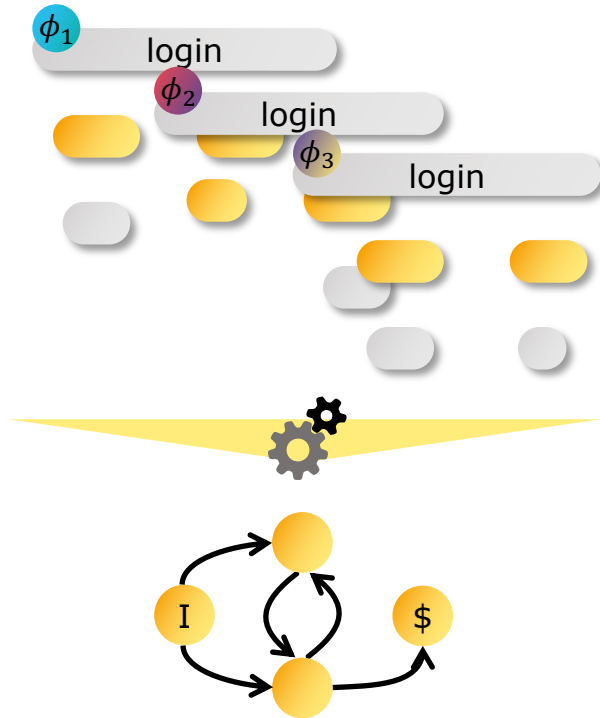

Model-based Tailoring

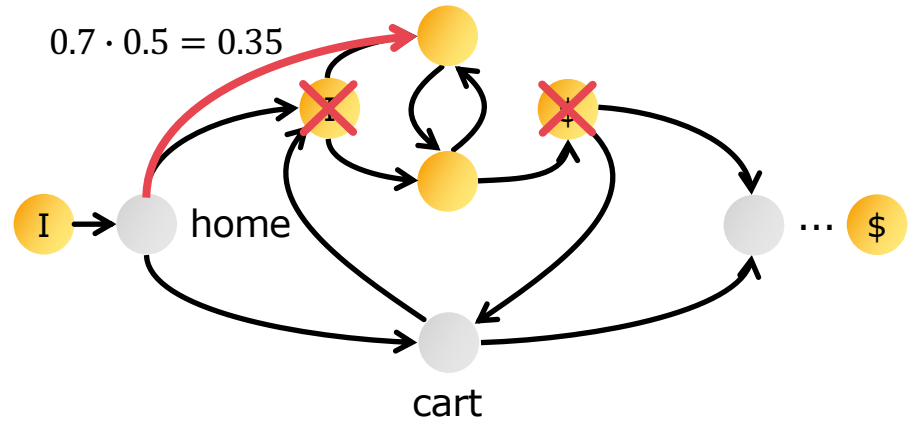
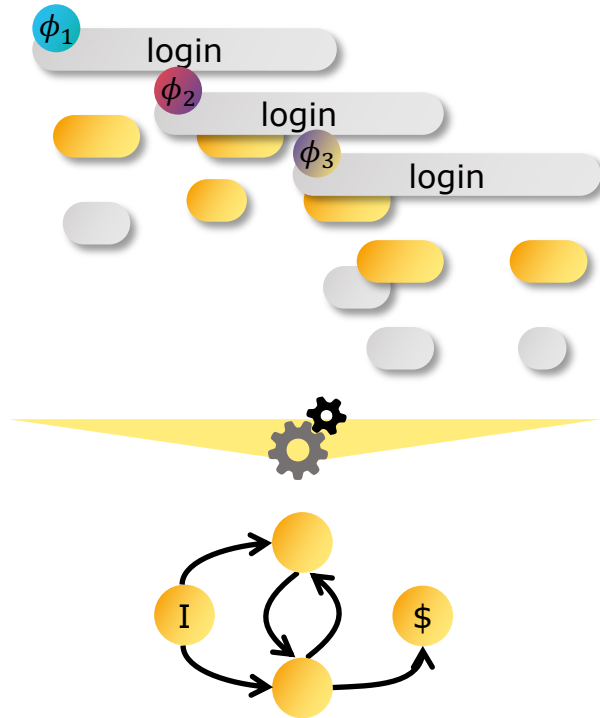

Model-based Tailoring

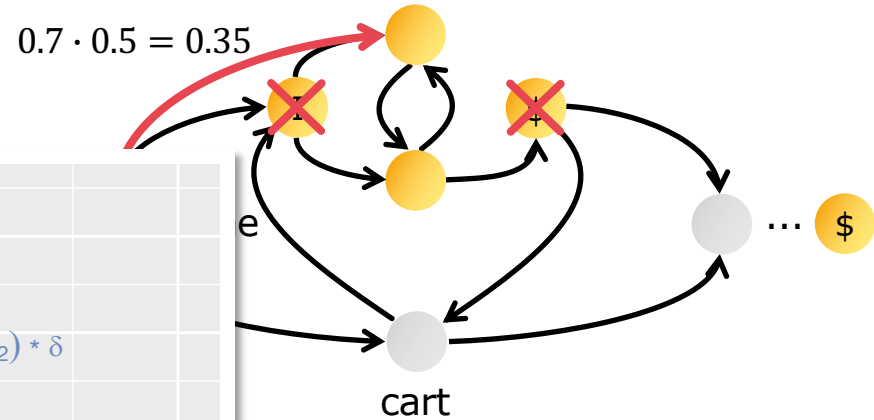
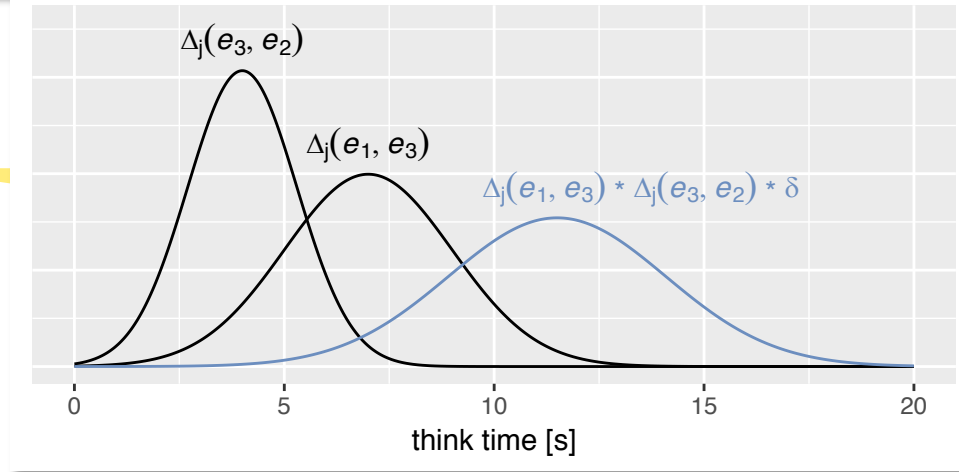
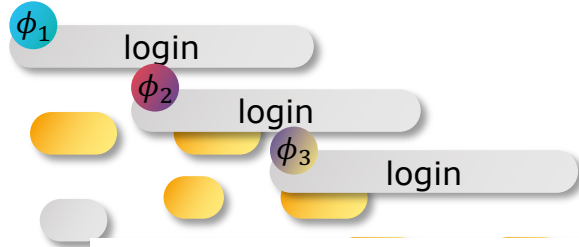

Model-based Tailoring

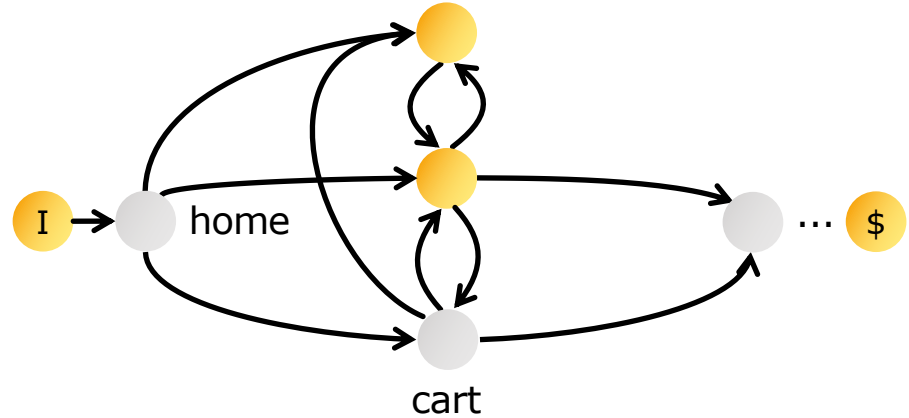
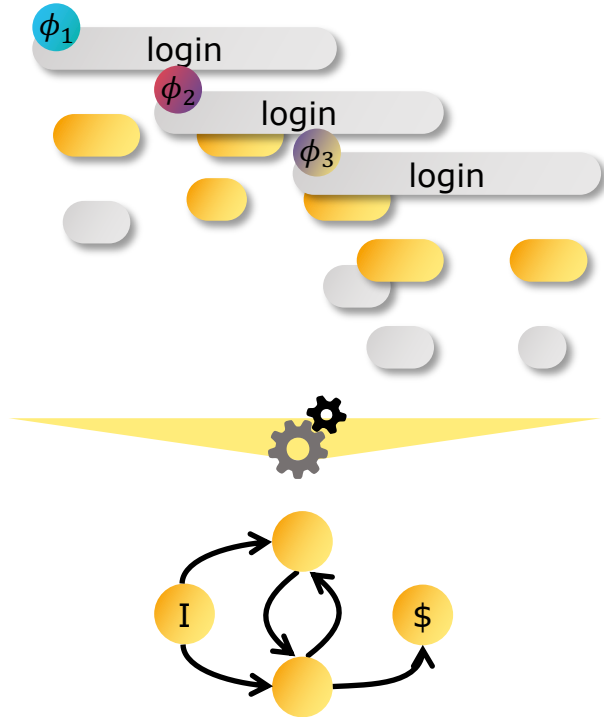

Evaluation: Research Questions

RQ1: Representativeness compared to untailed and request-based test

RQ2: Impairment of performance metrics

RQ4: Qualitative differences of tailored workload models

RQ3: Test execution time

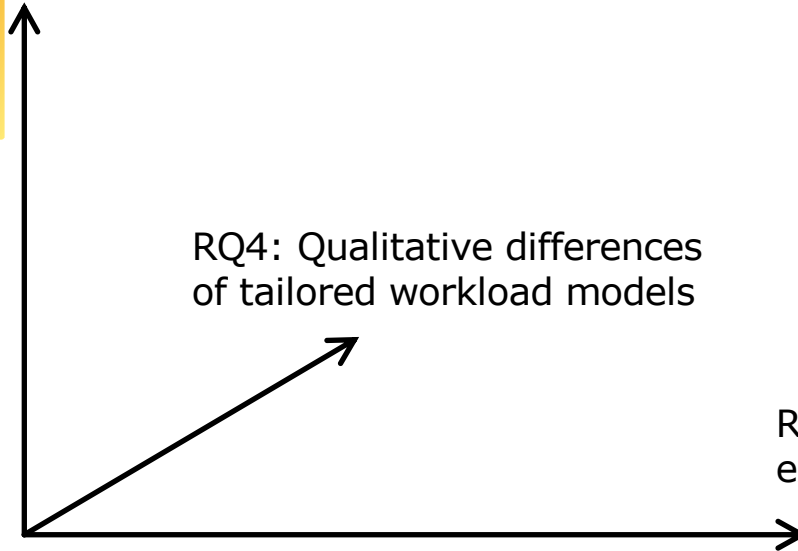

System Under Test: Sock Shop

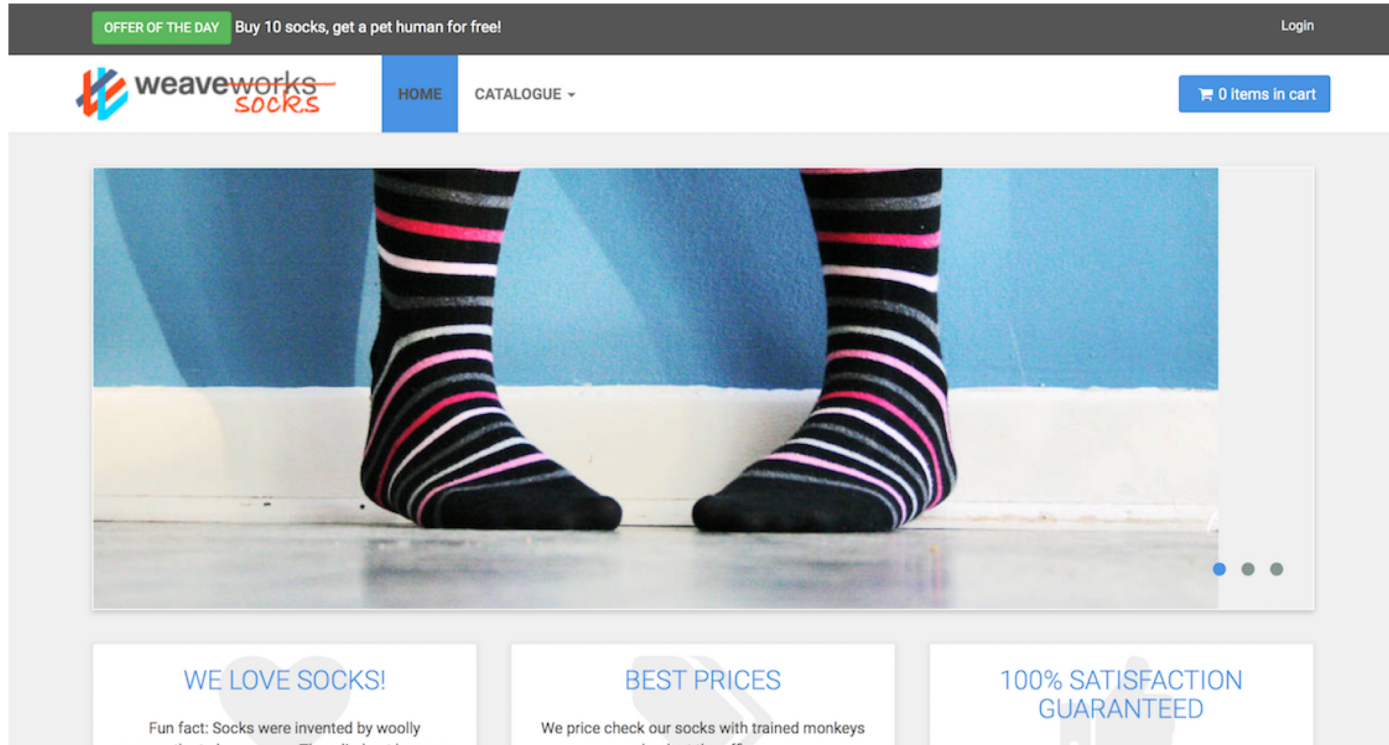

System Under Test: Sock Shop

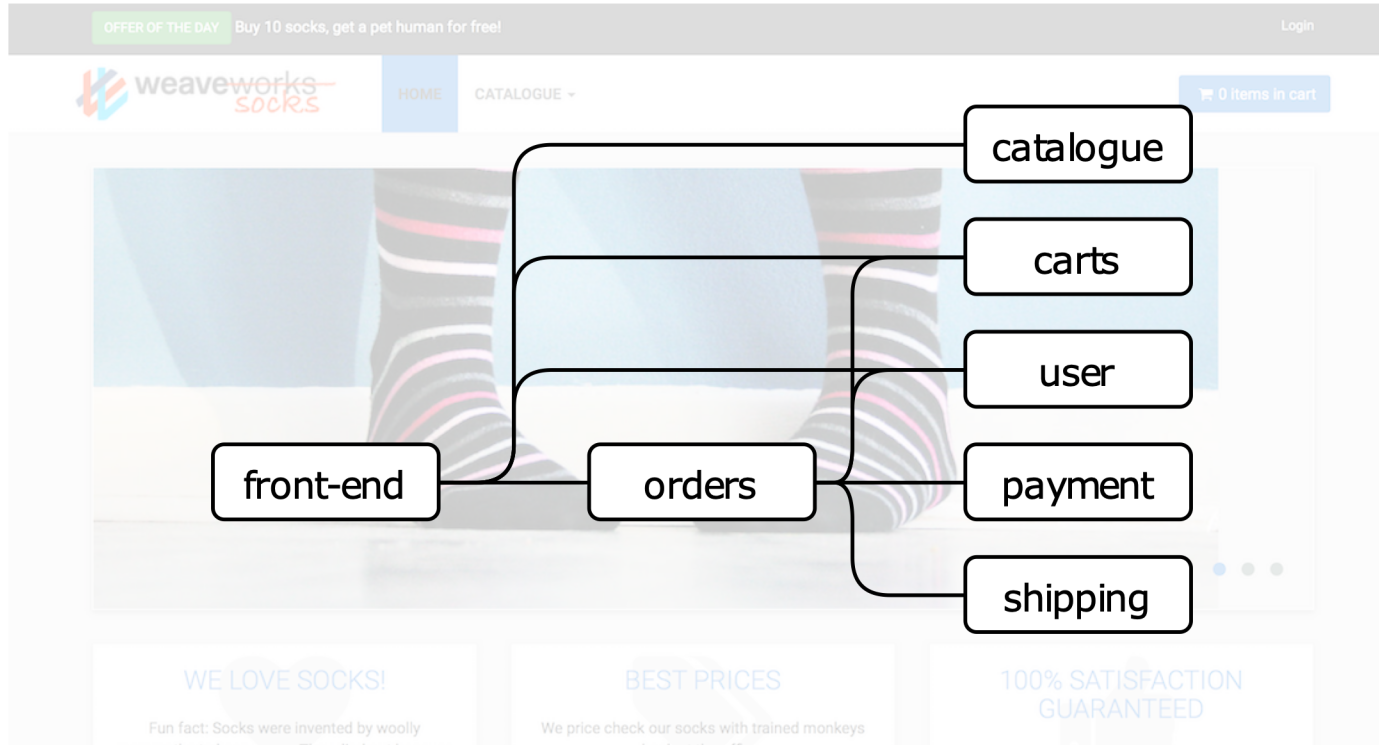

Aderaldo et al., 2017

image: <https://microservices-demo.github.io/>

Experimentation Process

reference
+
untailored
+
7x
{ log-based
model-based
request-based }
tailored

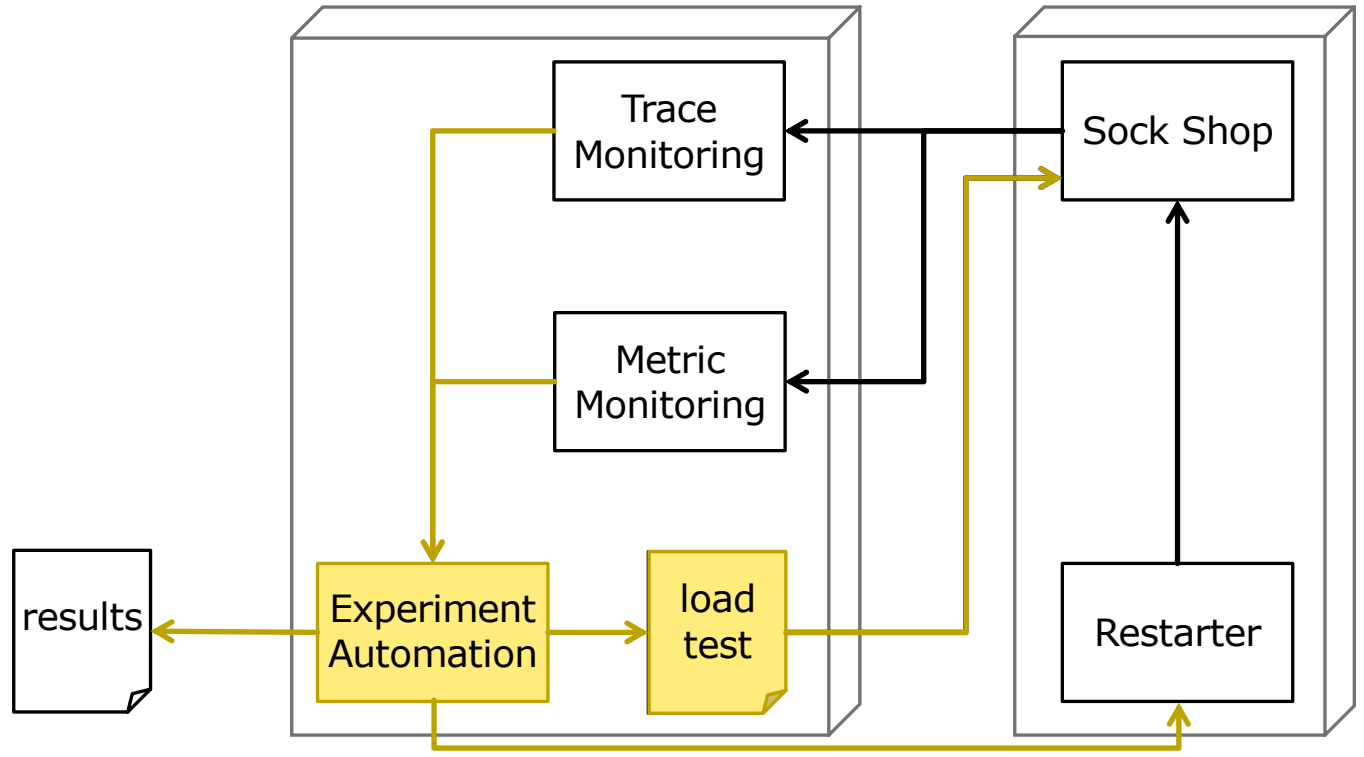

Representativeness Metric based on Kolmogorov Smirnov

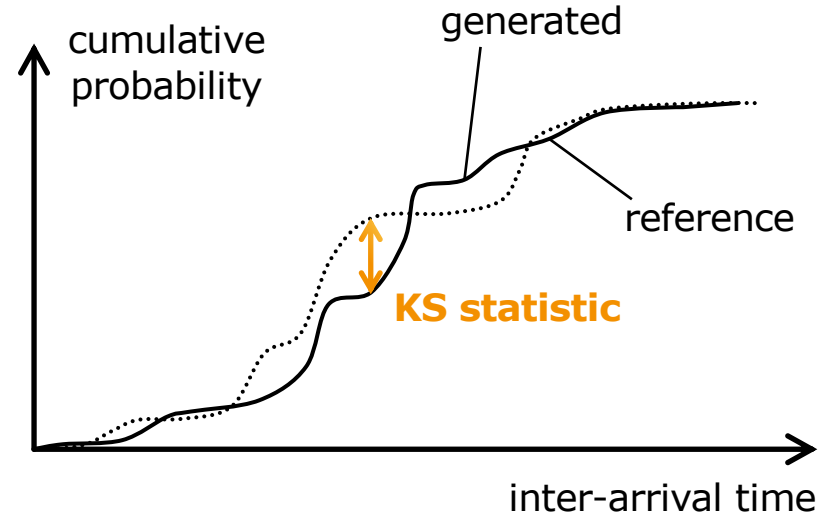
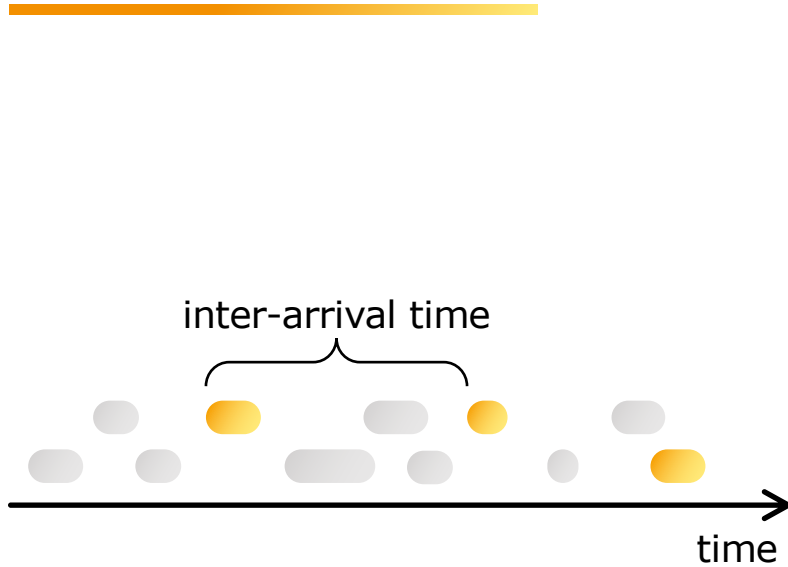

Model-based is Most Representative Tailoring

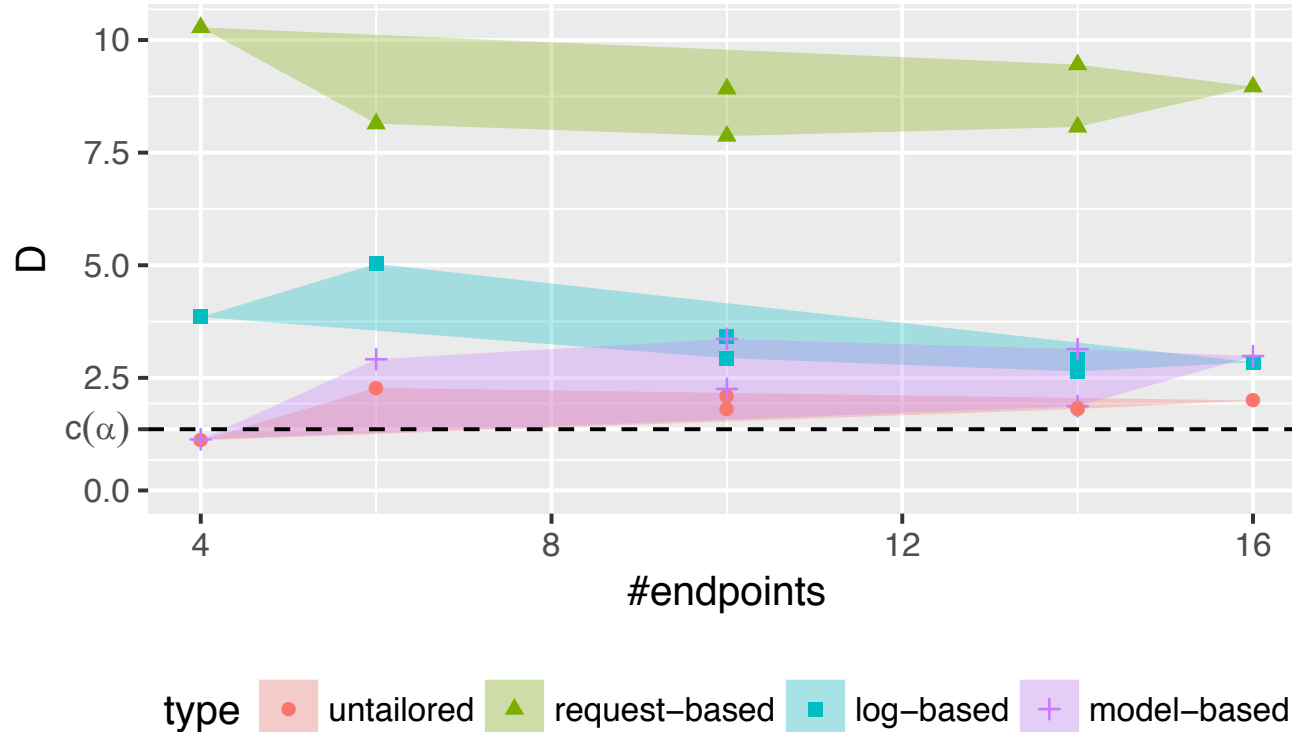

Evaluation Summary (Qualitative)

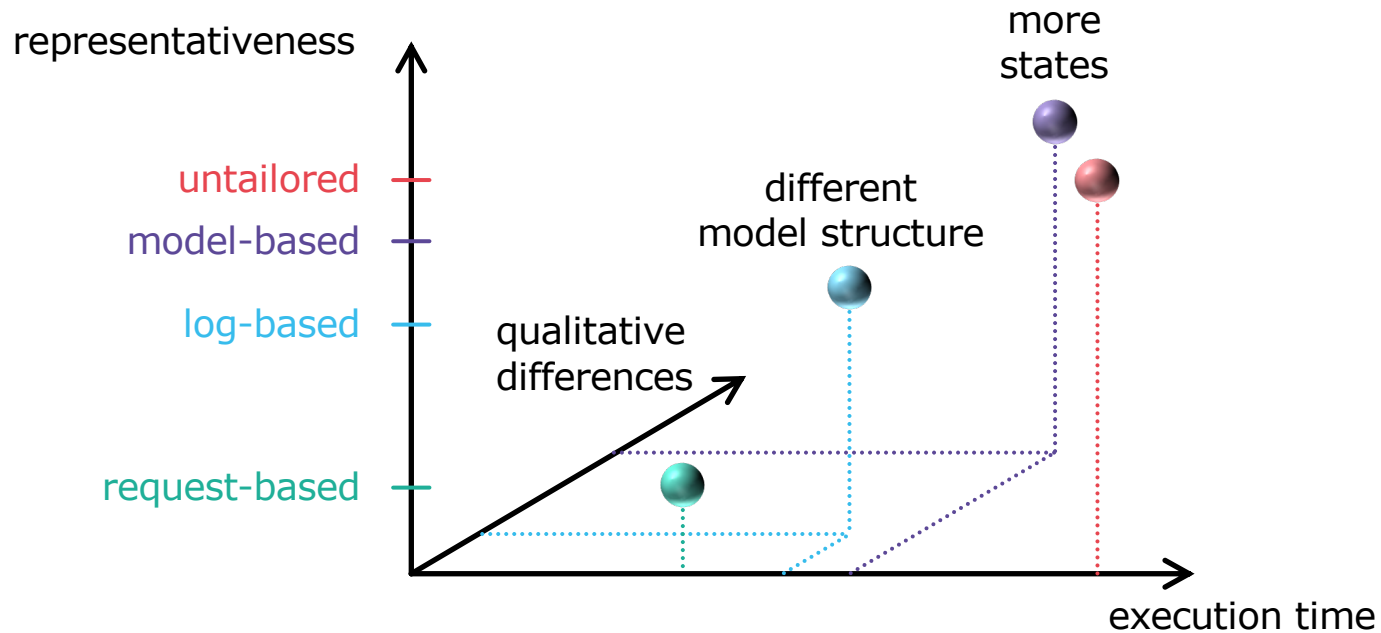

Replication Package:
<https://doi.org/10.5281/zenodo.3333367>

Workload Model Tailoring Allows Representative Load Testing for Microservices

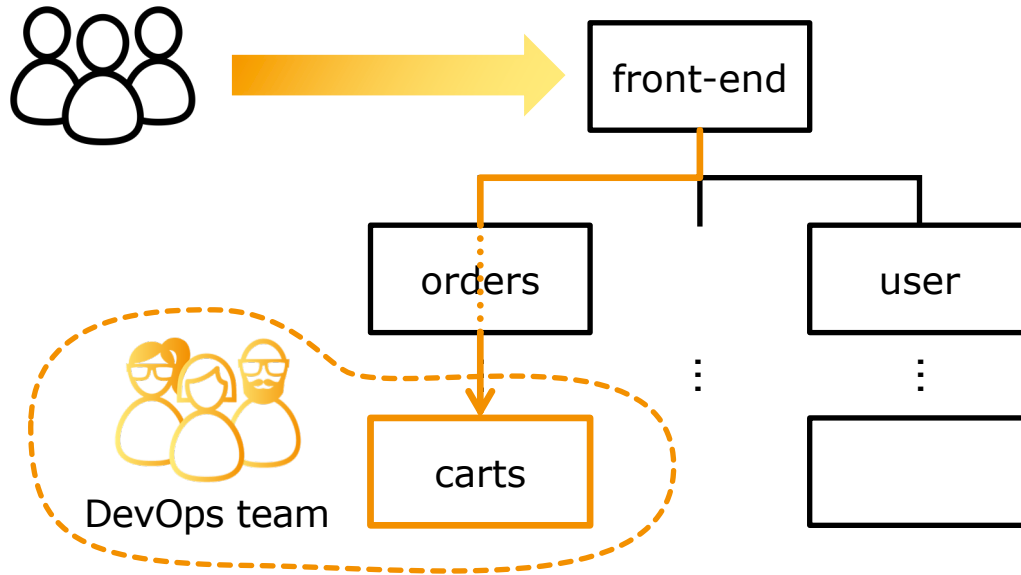

Workload Model Tailoring Allows Representative Load Testing for Microservices

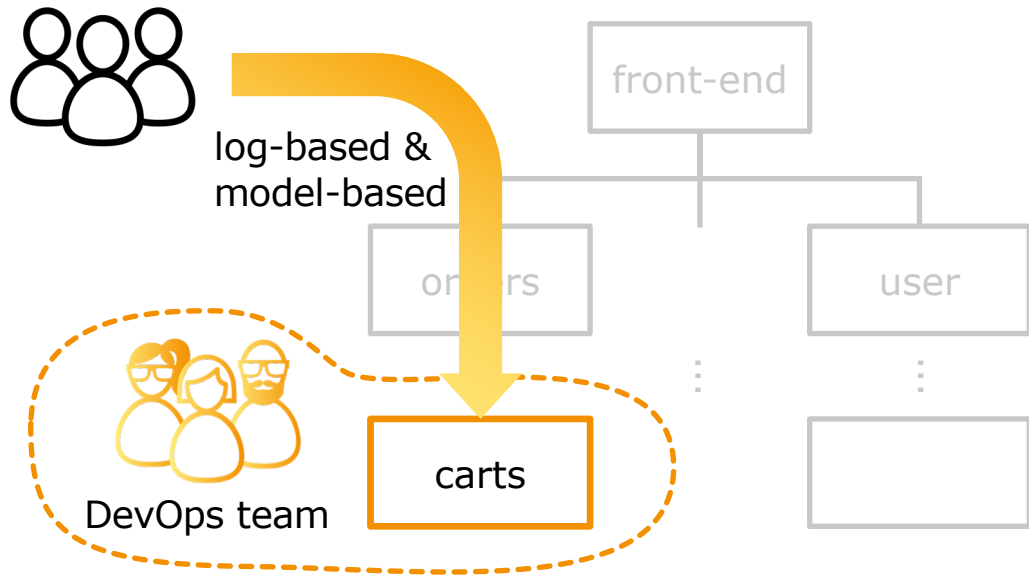

- ✓ less resources
- (✓) shorter execution
- ✓ representative
- ✓ DevOps ready
- 🔄 Industrial-scale study

References (I)

- Aderaldo, C.M., Mendonça, N.C., Pahl, C., Jamshidi, P.: Benchmark requirements for microservices architecture research. In: 1st IEEE/ACM International Workshop on Establishing the Community-Wide Infrastructure for Architecture-Based Software Engineering. pp. 8–13. ECASE@ICSE (2017)
- Baltas, N., Field, T.: Continuous Performance Testing in Virtual Time. In: Proceedings of the 9th International Conference on Quantitative Evaluation of Systems (QEST 2012). pp. 13–22. IEEE Computer Society (2012)
- Becker, S., Dencker, T., Happe, J.: Model-driven generation of performance prototypes. In: Performance Evaluation: Metrics, Models and Benchmarks. pp. 79–98 (2008)
- Bernardo, M., Cortellessa, V., Flamminj, M.: TwoEagles: A model transformation tool from architectural descriptions to queueing networks. In: Proceedings of the 8th European Performance Engineering Workshop (EPEW 2011). Lecture Notes in Computer Science, vol. 6977, pp. 265–279. Springer (2011)

References (II)

- Calzarossa, M.C., Massari, L., Tessera, D.: Workload characterization: A survey revisited. *ACM Computing Surveys* 48(3), 48:1–48:43 (2016)
- Cohn, M.: *Succeeding with Agile: Software Development Using Scrum*. Addison-Wesley Professional (2009)
- Cortellessa, V., Mirandola, R.: PRIMA-UML: A performance validation incremental methodology on early UML diagrams 44(1), 101–129 (2002)
- Denning, P.J., Buzen, J.P.: The operational analysis of queueing network models. *ACM Comput. Surv.* 10(3), 225–261 (1978)
- Ferrari, D.: On the foundations of artificial workload design. *SIGMETRICS Perform. Eval. Rev.* 12(3), 8–14 (1984)
- Field, T., Chatley, R., Wei, D.: Software performance testing in virtual time. In: *Companion of the 2018 ACM/SPEC International Conference on Performance Engineering*. pp. 173–174. ICPE '18 (2018)

References (III)

- Graf, I.M.: Transformation Between Different Levels of Workload Characterization for Capacity Planning. In: Proceedings of the ACM SIGMETRICS Conference on Measurement and Modeling of Computer Systems (SIGMETRICS 1987). pp. 195–204. ACM (1987)
- Horky, V., Libič, P., Marek, L., Steinhauser, A., Tuma, P.: Utilizing performance unit tests to increase performance awareness. In: Proceedings of the 6th ACM/SPEC International Conference on Performance Engineering. pp. 289–300. ICPE '15 (2015)
- Koziolok, H., Reussner, R.H.: A model transformation from the Palladio Component Model to layered queueing networks. In: Proceedings of the SPEC International Performance Evaluation Workshop (SIPEW 2008).
- Menascé, D.A., Almeida, V.A.F.: Capacity Planning for Web Services: Metrics, Models and Methods. Prentice Hall (2002)

References (IV)

- Ruffo, G., Schifanella, R., Sereno, M., Politi, R.: Walty: a user behavior tailored tool for evaluating web application performance. In: Proceedings of the 3rd IEEE International Symposium on Network Computing and Applications, pp. 77–86 (2004)
- Shams, M., Krishnamurthy, D., Far, B.H.: A model-based approach for testing the performance of web applications. In: Proc. SOQUA 2006 (2006)
- Versteeg, S., Du, M., Schneider, J.G., Grundy, J., Han, J., Goyal, M.: Opaque service virtualisation: A practical tool for emulating endpoint systems. In: Proceedings of the 38th International Conference on Software Engineering (ICSE 2016). pp. 202–211 (2016)
- Vögele, C., van Hoorn, A., Schulz, E., Hasselbring, W., Krcmar, H.: WESSBAS: extraction of probabilistic workload specifications for load testing and performance prediction - a model-driven approach for session-based application systems. *Software and System Modeling* 17(2), 443–477 (2018)